

# 1/8 Round Spacers

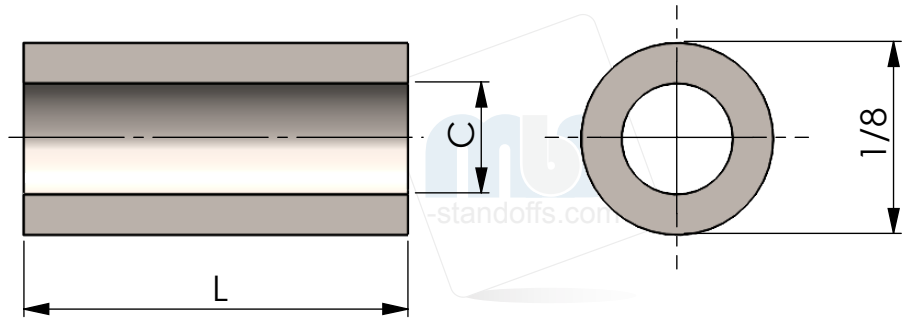

**Create a part number:**

Length	Clearance	Material	Finish
FCXXXX	XX	XX	XX
_____ - _____ - _____ - _____			

✓	FMXXXX	Length (L)
	FC1100	1/8
	FC1101	3/16
	FC1102	1/4
	FC1103	5/16
	FC1104	3/8
	FC1105	7/16
	FC1106	1/2

✓	Code (XX)	C + .010
	0	.064
	2	.090

✓ Material Code (XX)	
A	Aluminum
B	Brass
S	Steel
SS	Stainless Steel
N	Nylon

A, B, S, SS	0 - Plain
B, S	5 - Nickel Plate (QQ-N-290)
A	6 - Iridite #14 Gold (MIL-C-5541E)
A	7 - Iridite Clear (MIL-C-5541E)
A	9 - Alodine 1200
B, S	12 - Zinc Clear (ASTM-B-633)
B, S	16 - Electro Tin (MIL-T-10727 TYPE 1)
SS	20 - Passivation (MIL-F-14072D)
A	22 - Clear Anodize (MIL-A-8625-TYPE2) (Sulphuric) Hot Water Seal (Clear)
A	24 - Black Anodize (MIL-A-8625)
B, S, SS	26 - Black Oxide
B, S	28 - Zinc Yellow (ASTM-B-633)



5046 W Linebaugh Ave  
Tampa, FL, 33624  
sales@mbs-standoffs.com  
Mbs-Standoffs.com  
P: (813) 938-6025  
F: (813) 425-9007

**Tolerances**  
Unless otherwise Specified  
.xxx +/- .005  
.xx +/- .010  
Angular +/- 1 Degree  
Linear +/- .005  
**Break all sharp edges**

Source Control Drawing:  
To be produced by  
mbs-standoffs

This document is the property of mbs-standoffs Inc. and shall not be reproduced, distributed, or used as a basis for manufacturing without written permission from mbs-standoffs Inc.