

[1"]
 $\phi 25\text{mm}$

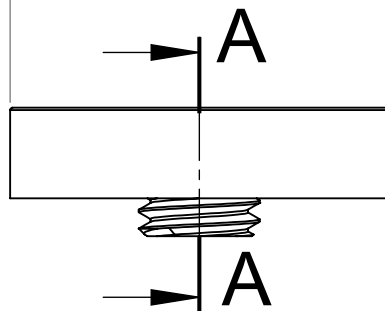

[1/4"]
 6mm

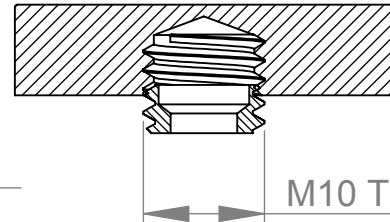

M10 Thread

SECTION A-A

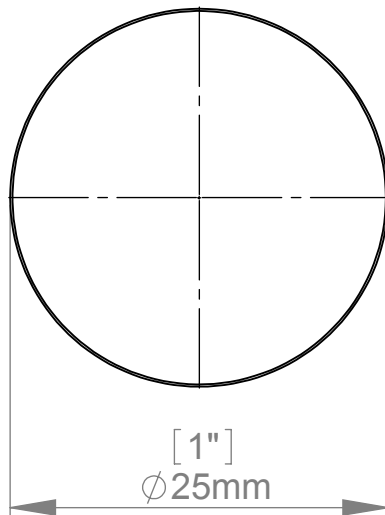

[1"]
 $\phi 25\text{mm}$

Item	Qty.	Description
[1]	1	SC25SSS Cap
[2]	1	M10xL3.2mm Screw

Title : **SC25SSS**

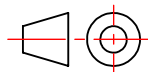

Scale : 2:1

Mbs R&D

Sizes : Letter Portrait

Customer:



Mbs Standoffs
 8420 Benjamin Rd
 Tampa, FL 33634
 USA
 813 938 6075

Material:

Finish

Qty :

Rep :

N°programme laser

N°prog. Mécanum.

N° Plan : SC25SSS