

Attention  
Reverse Threaded  
For Tamper Proof Perposes

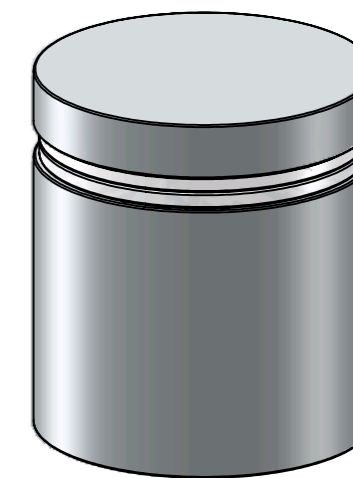
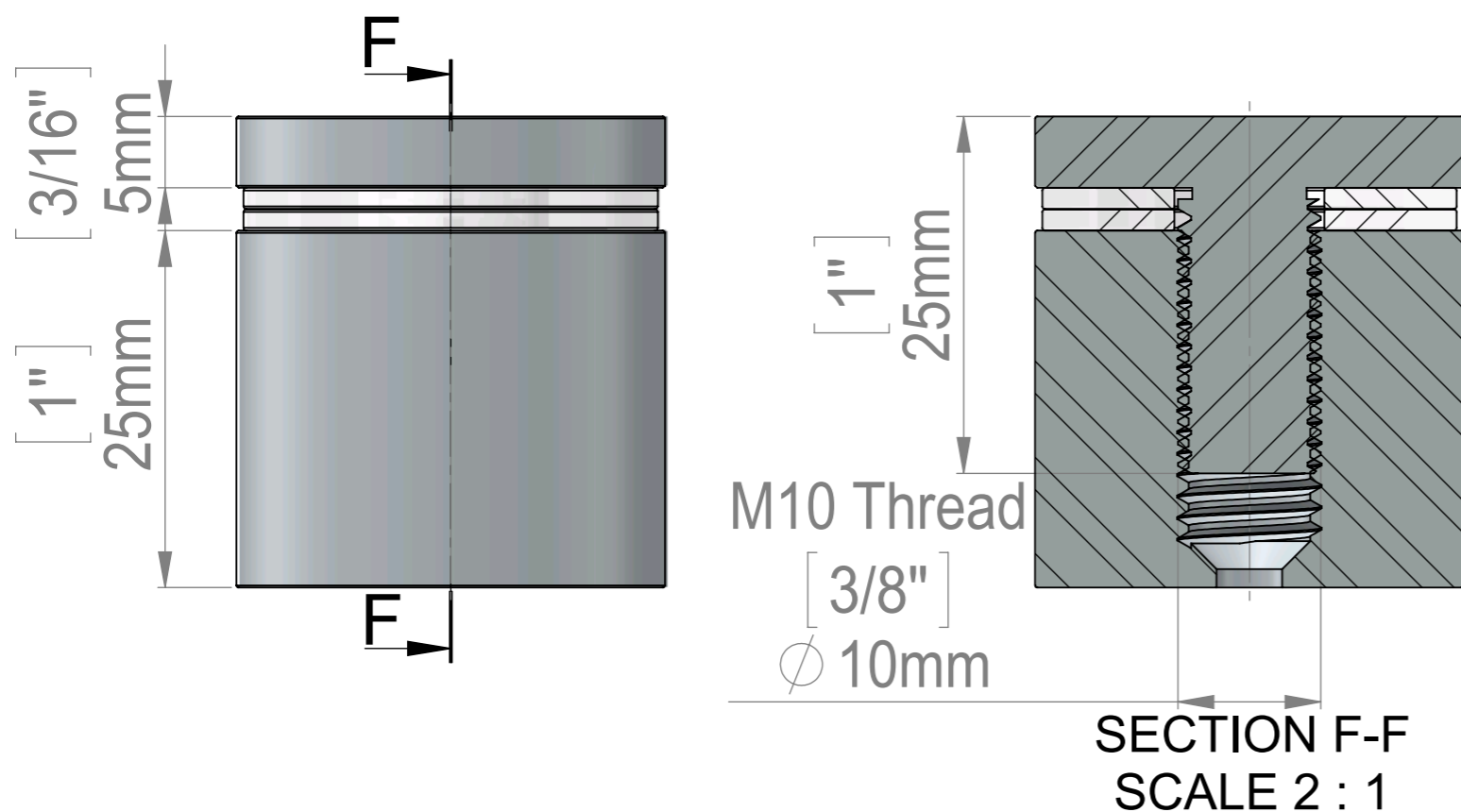
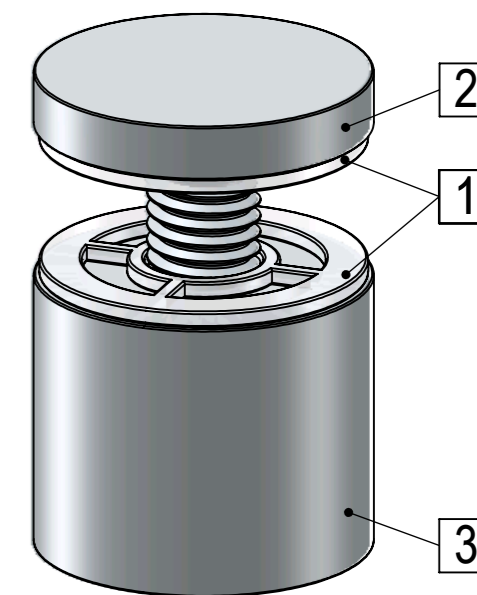

ITEM NO.	PART NUMBER	DESCRIPTION	QTY.
1	FAH30_Washer		2
2	HM1127A(FHA30-25)-Reverse_Thread		1
3	FAH30-30_Body-30x25-Reverse_Thread		1

Title : FAH30-30		Scale : 1.5:1		Mbs R&D	
		Sizes : Letter Landscape		Customer:	
Material:		Finish		Qty :	Rep :
N°programme laser		N°prog. Mécanum.		N° Plan : FAH30-30	

Mbs Standoffs  
6420 Benjamin Rd  
Tampa, FL 33634  
USA  
813-938-6025