

Attention
Reverse Threaded
For Tamper Proof Purposes

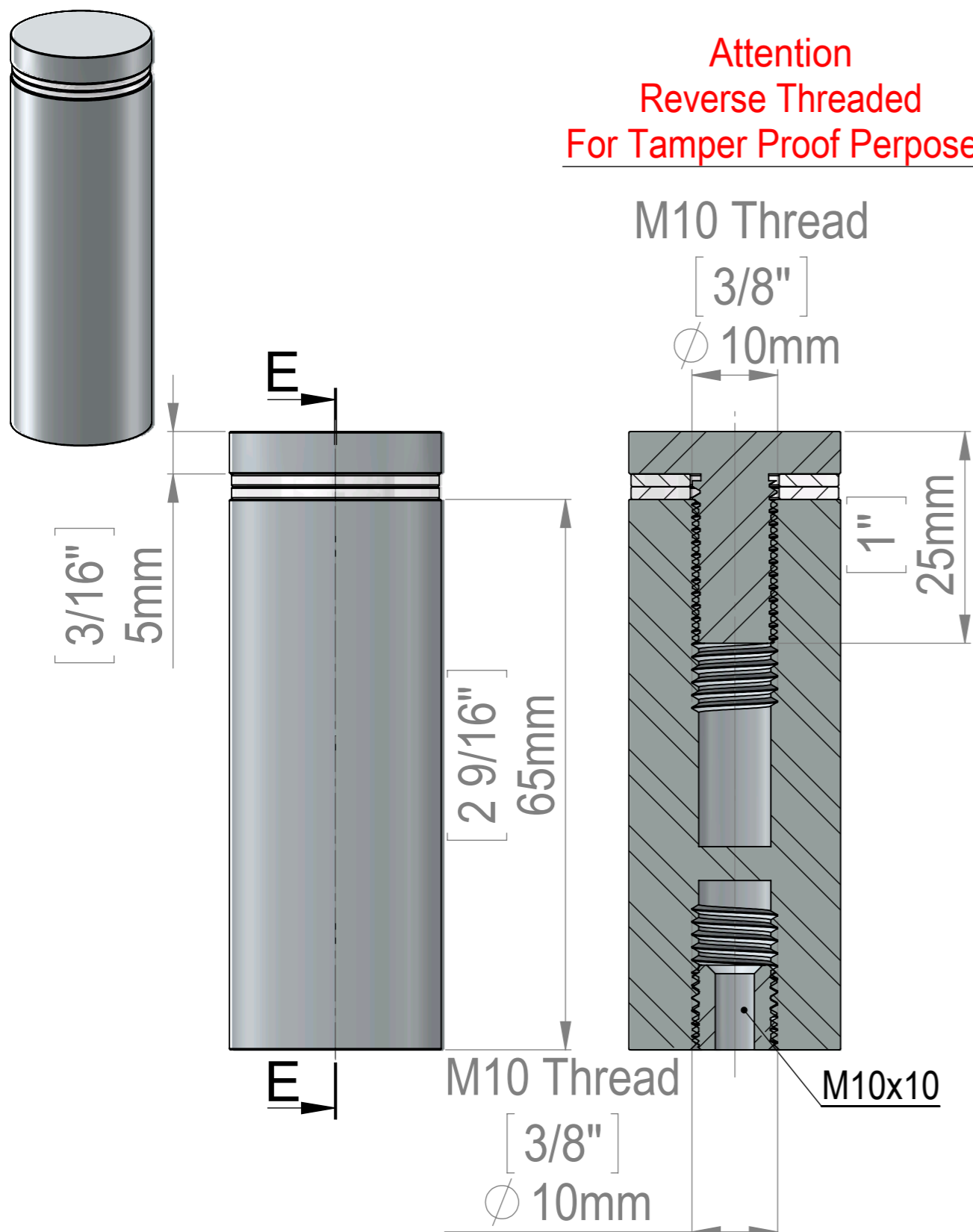

SECTION E-E
SCALE 1.5 : 1

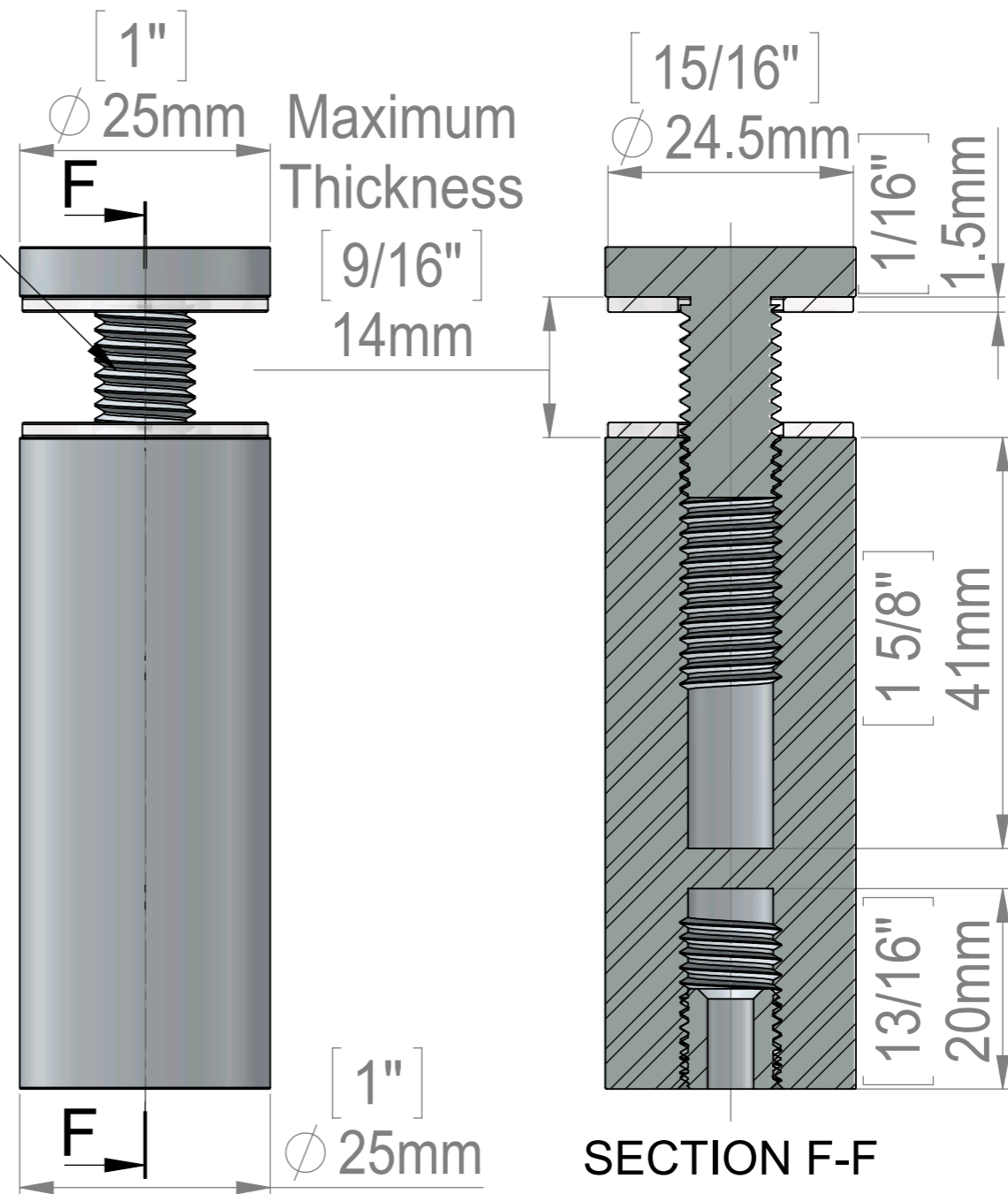

SECTION F-F
SCALE 1.5 : 1

ITEM NO.	PART NUMBER	DESCRIPTION	QTY.
1	FAH25_Washer		2
2	HM1122A(FHA25-25)-Reverse_Thread		1
3	FAH25-70_Body-25x65-Reverse_Thread		1
4	M10x10mm-Screw		1

Title : FAH25-70		Scale : 1:1		Mbs R&D	
		Sizes : Letter Landscape		Customer:	
Material:		Finish		Qty :	Rep :
Mbs Standoffs 6420 Benjamin Rd Tampa, FL 33634 USA 813-938-6025		N°programme laser		N°prog. Mécanum.	
				N° Plan : FAH25-70	