

Attention
Reverse Threaded
For Tamper Proof Purposes

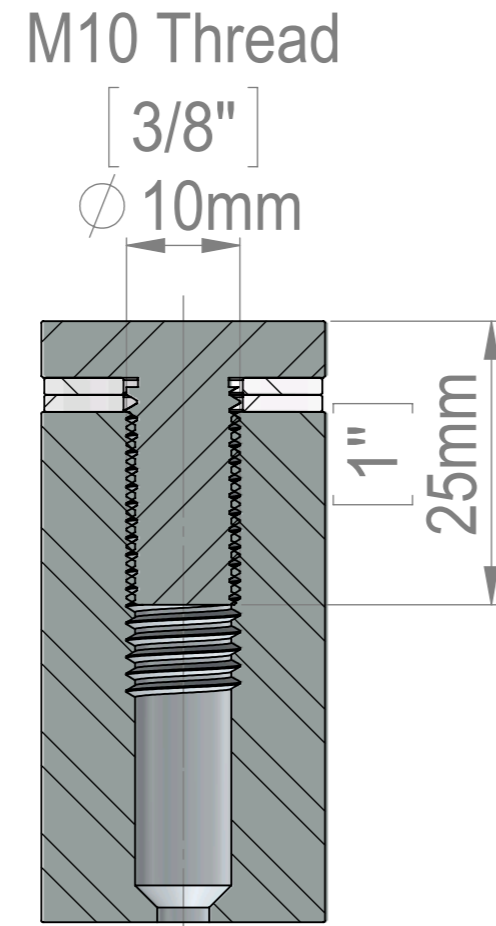

SECTION F-F
SCALE 1.5 : 1

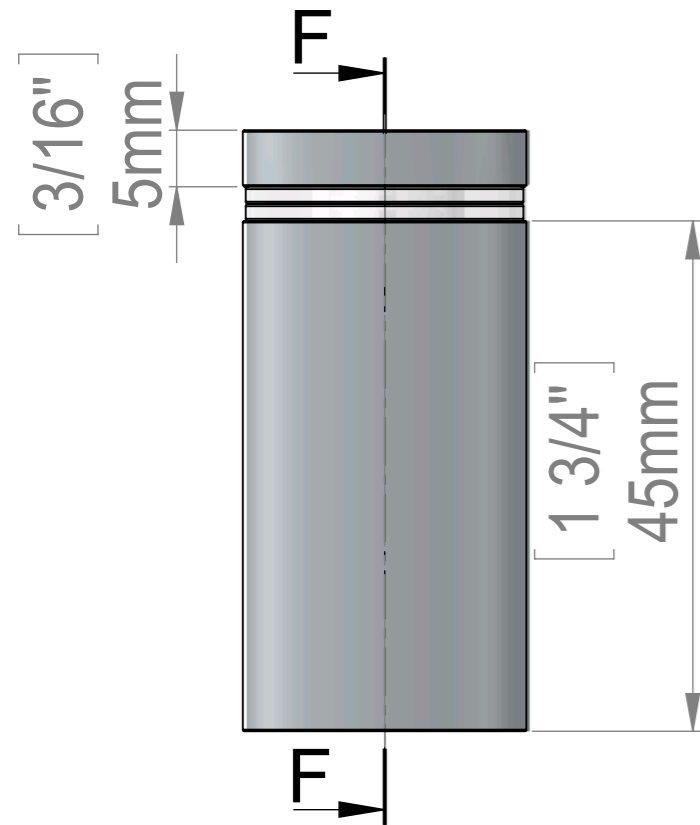
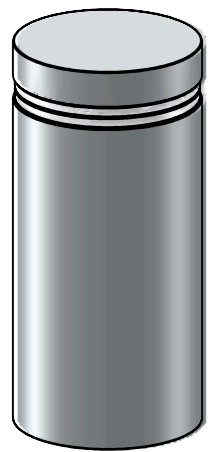
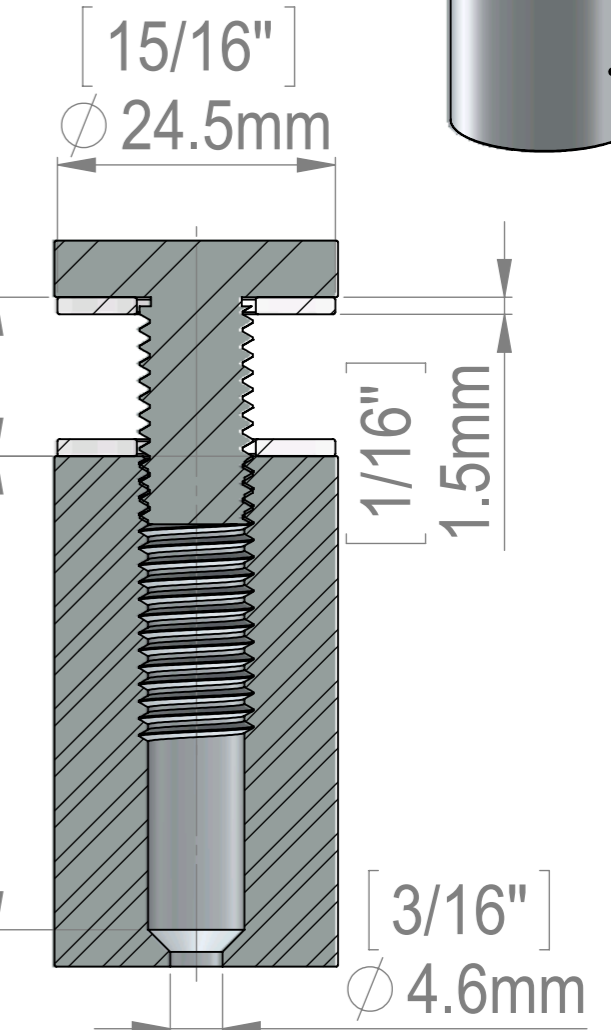
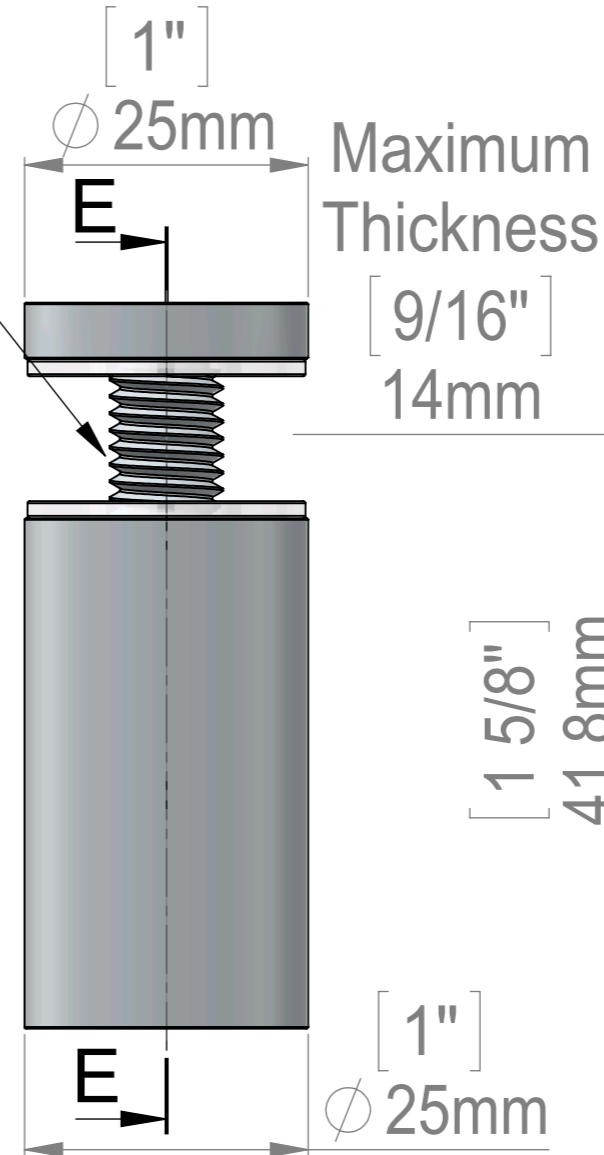

SECTION E-E
SCALE 1.5 : 1

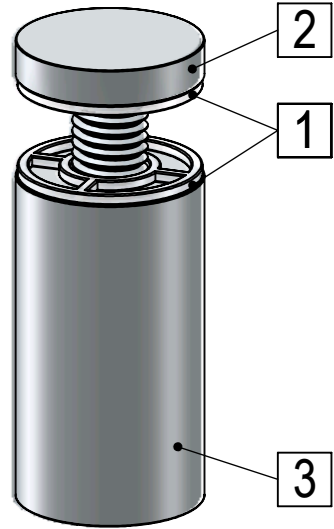

ITEM NO.	PART NUMBER	DESCRIPTION	QTY.
1	FAH25_Washer		2
2	HM1122A(FHA25-25)-Reverse_Thread		1
3	FAH25-50_Body-25x45-Reverse_Thread		1

Title : FAH25-50		Scale : 1:1		Mbs R&D	
		Sizes : Letter Landscape		Customer:	
Material:		Finish		Qty :	Rep :
N°programme laser		N°prog. Mécanum.		N° Plan : FAH25-50	

Mbs Standoffs
6420 Benjamin Rd
Tampa, FL 33634
USA
813-938-6025