

Maximum Thickness
 $9/16"$
 14mm

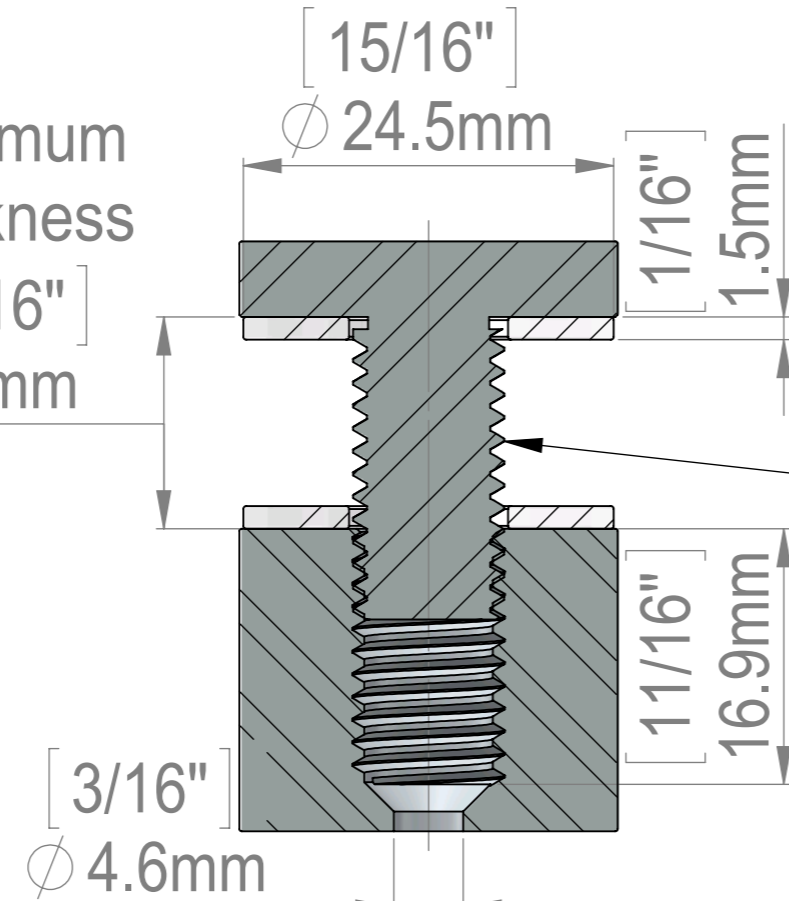

SECTION E-E
 SCALE 2 : 1
 M10 Thread

Attention
 Reverse Threaded
 For Tamper Proof Purposes

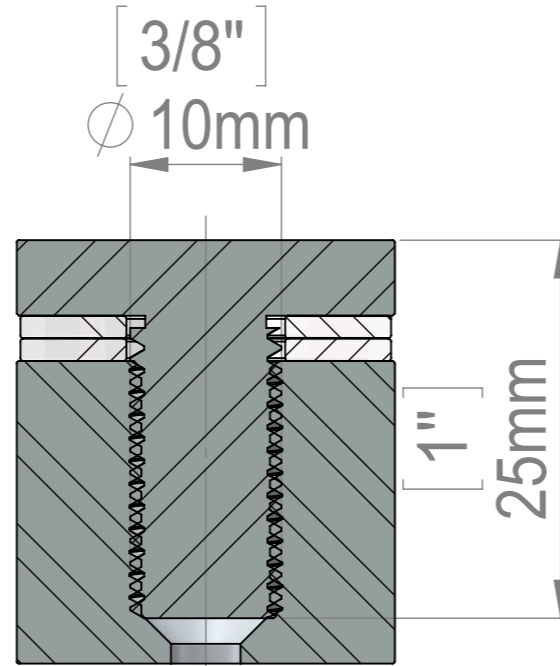
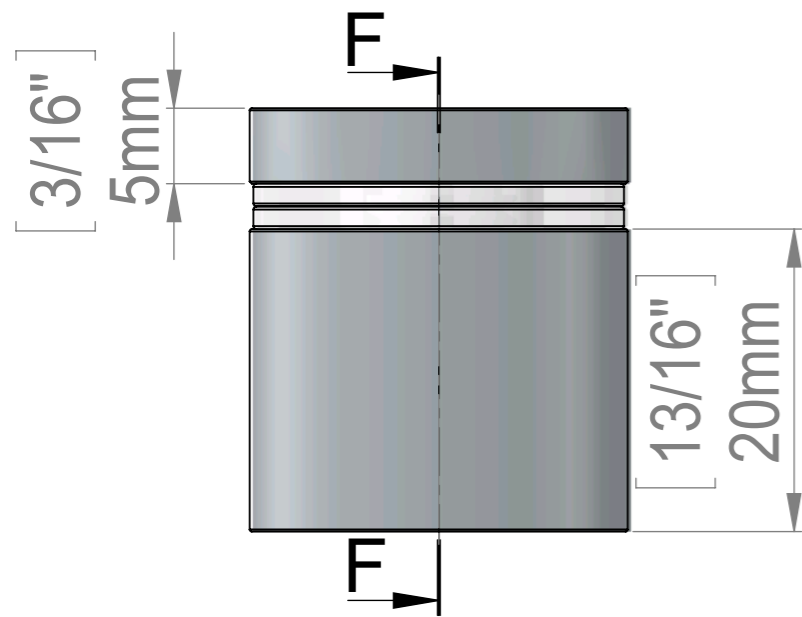
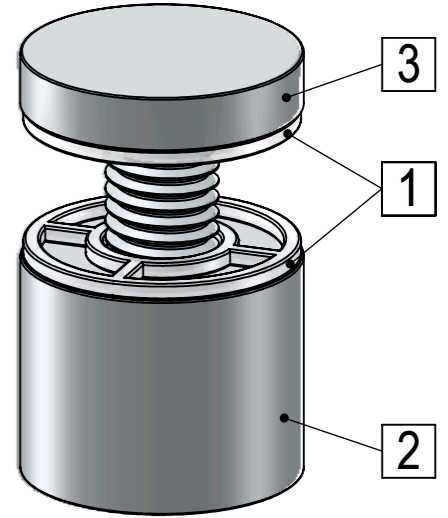

SECTION F-F
 SCALE 2 : 1



ITEM NO.	PART NUMBER	DESCRIPTION	QTY.
1	FAH25_Washer		2
2	FAH25-25_Body-25x20-Reverse_Thread		1
3	HM1122A(FHA25-25)-Reverse_Thread		1

Title : FAH25-25		Scale : 1.5:1		Mbs R&D	
		Sizes : Letter Landscape		Customer:	
Mbs Standoffs 6420 Benjamin Rd Tampa, FL 33634 USA 813-938-6025		Material:		Qty : Rep :	
		N°programme laser		N°prog. Mécanum.	
		Finish		N° Plan : FAH25-25	