

Attention
Reverse Threaded
For Tamper Proof Purposes

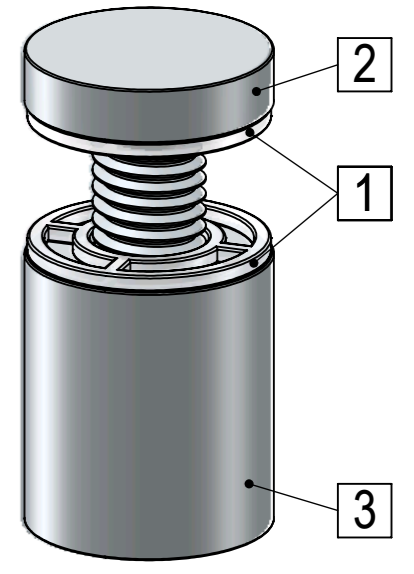

ITEM NO.	PART NUMBER	DESCRIPTION	QTY.
1	FAH22_Washer		2
2	HM1117A(FHA22-25)-Reverse_Thread		1
3	FAH22-30_Body-22x25-Reverse_Thread		1

Title : FAH22-30		Scale : 1.5:1		Mbs R&D	
		Sizes : Letter Landscape		Customer:	
Material:		Finish		Qty :	Rep :
N°programme laser		N°prog. Mécanum.		N° Plan : FAH22-30	

Mbs Standoffs
6420 Benjamin Rd
Tampa, FL 33634
USA
813-938-6025