

SECTION E-E
SCALE 1.5 : 1

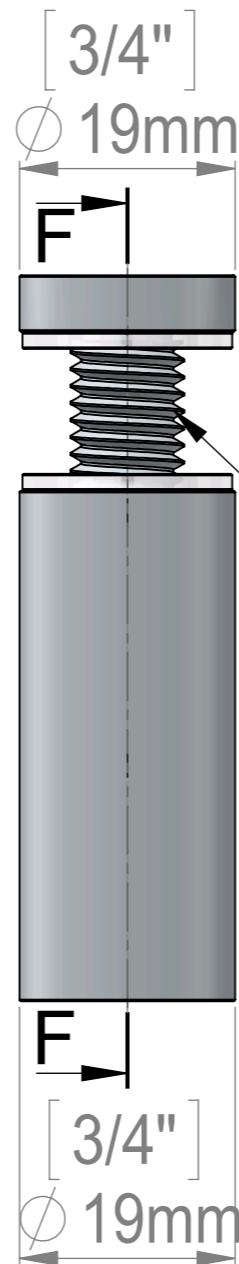

Maximum Thickness
[9/16"]
14mm

Attention
Reverse Threaded
For Tamper Proof Purposes

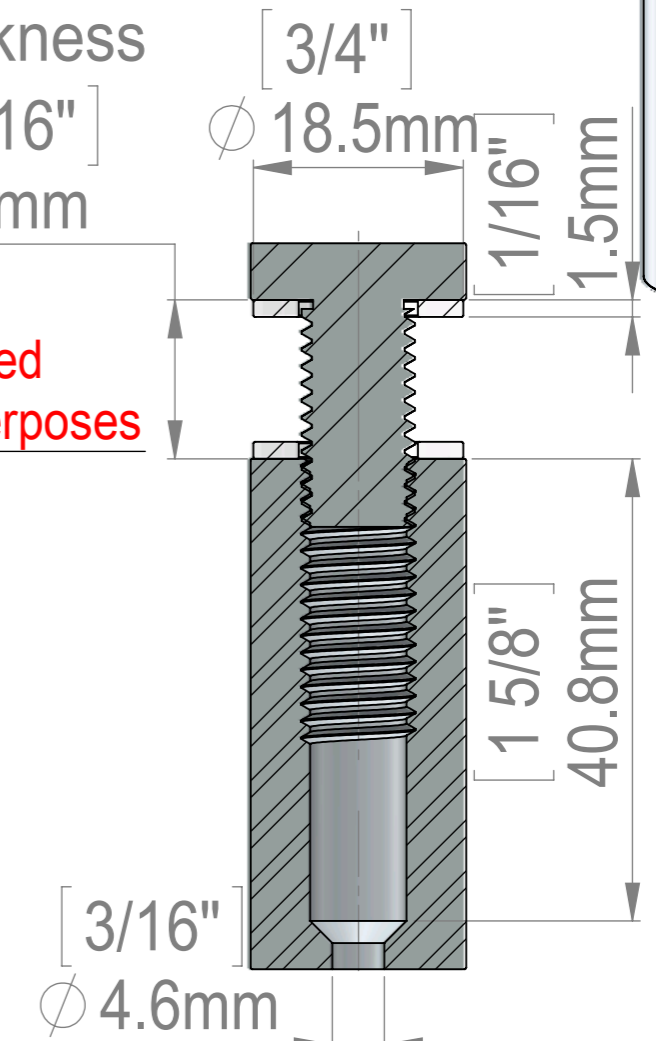

SECTION F-F
SCALE 1.5 : 1

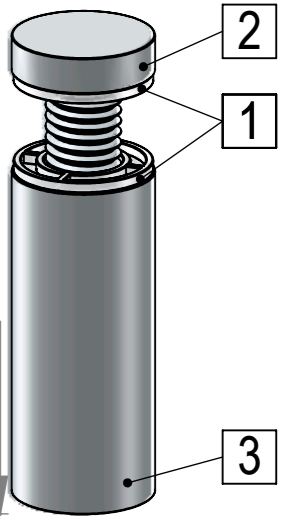

ITEM NO.	PART NUMBER	DESCRIPTION	QTY.
1	FAH19_Washer		2
2	HM1112A(FHA19-25)-Reverse_Thread		1
3	AL19-50_Body-19x45-Reverse_Thread		1

Title : FAH19-50		Scale : 1:1		Mbs R&D	
		Sizes : Letter Landscape		Customer:	
Mbs Standoffs 6420 Benjamin Rd Tampa, FL 33634 USA 813-938-6025		Material:		Qty : Rep :	
N°programme laser		N°prog. Mécanum.		N° Plan : FAH19-50	