

Maximum Thickness
9/16" 14mm

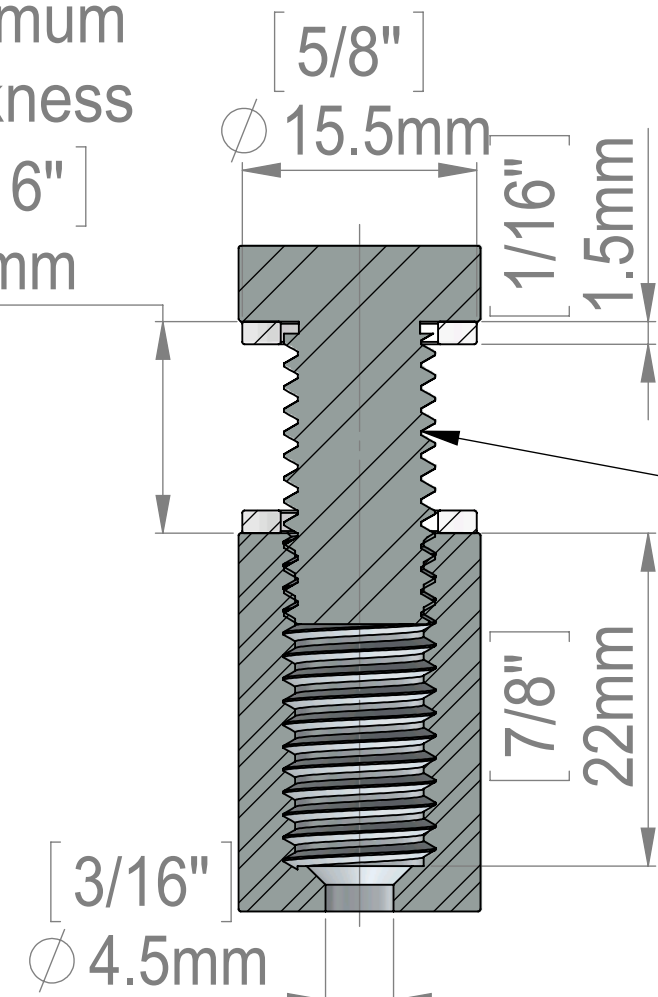

SECTION E-E
SCALE 2 : 1
M10 Thread

Attention
Reverse Threaded
For Tamper Proof Purposes

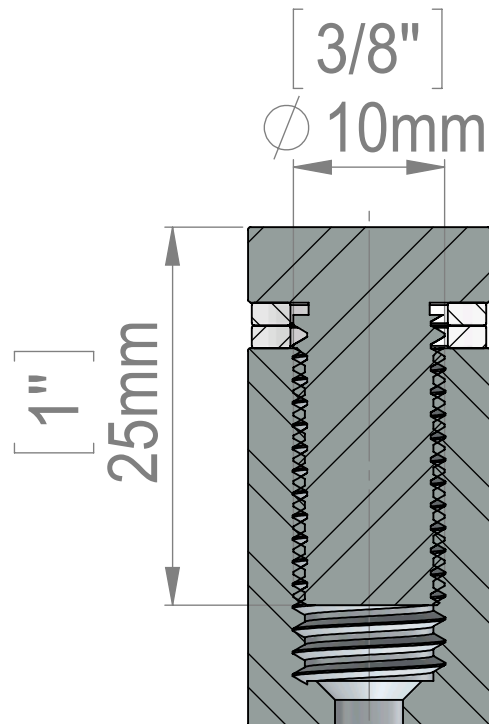
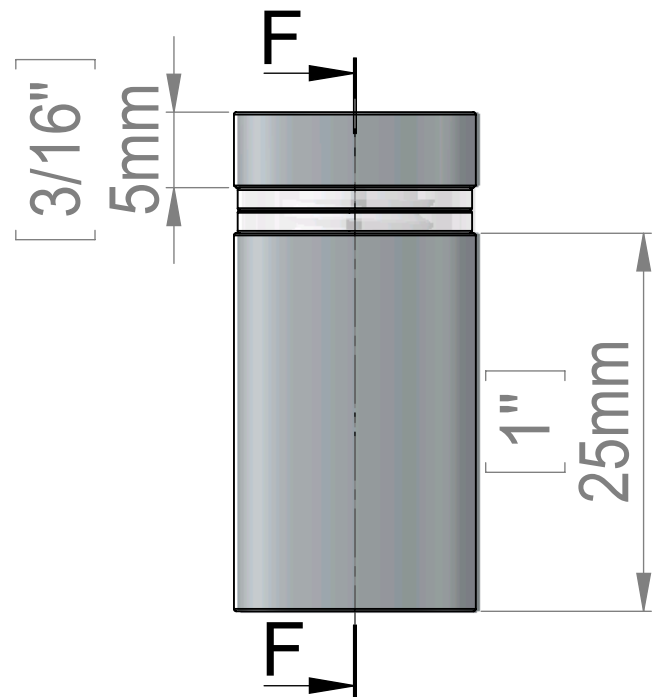
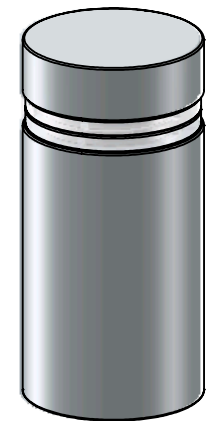
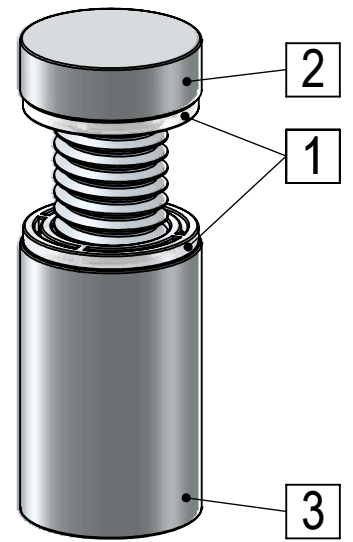

SECTION F-F
SCALE 2 : 1

| ITEM NO. | PART NUMBER | DESCRIPTION | QTY. |
|----------|------------------------------------|-------------|------|
| 1 | FAH16_Washer | | 2 |
| 2 | HM1107A(FHA16-25)-Reverse_Thread | | 1 |
| 3 | FAH16-30_Body-16x25-Reverse_Thread | | 1 |

| | | | | | |
|-------------------|--|--------------------------|--|--------------------|-------|
| Title : FAH16-30 | | Scale : 1.5:1 | | Mbs R&D | |
| | | Sizes : Letter Landscape | | Customer: | |
| Material: | | Finish | | Qty : | Rep : |
| N°programme laser | | N°prog. Mécanum. | | N° Plan : FAH16-30 | |



Mbs Standoffs
6420 Benjamin Rd
Tampa, FL 33634
USA
813-938-6025